

ACCESSORIES

Sampling probe

DESCRIPTION: They are accessories used as part of the instrumentation in all those applications where sampling of the process directly from the pipe and its conduction to the analyzer in the minimum time is required, where high pressures and temperatures discourage direct intervention without pressure control measures, vent plugs as well as controlling the interaction of particles present in the environment and that can hinder the analysis of the process.

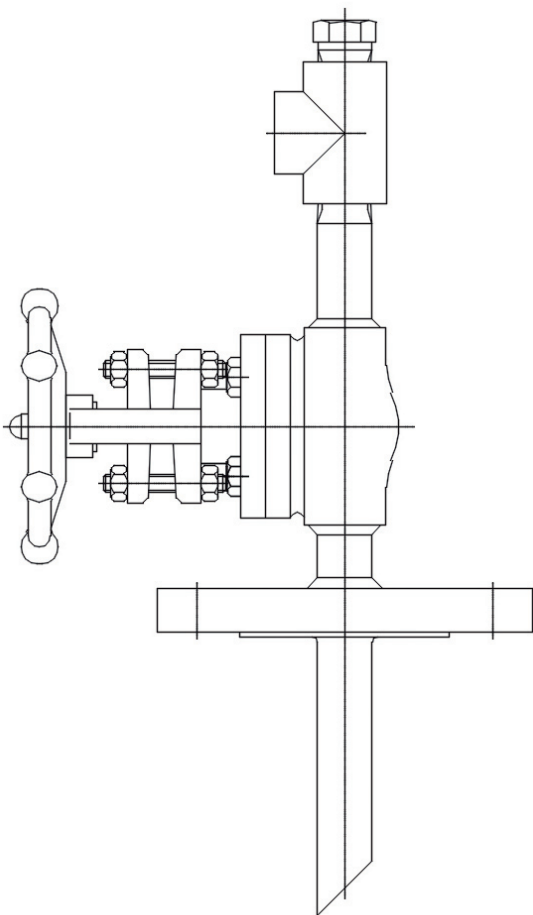

APPLICATIONS

- Process piping systems.
- Analyzers.
- In all types of industrial plants such as:
 - Power generation.
 - Chemical and petrochemical industries.
 - Renewable energies.
 - Food industry.
 - Paper factories.
 - Water treatment.

MANUFACTURING

- Design standards:	ASME B36.10 ASME BPVC VIII ASME IX ASME B16.34
- Materials:	AISI-316 (Others on request).
- Manufacturing sizes:	According to applicable specifications or standards.
- Types of connections:	NPT, Socket-welding, Butt welding, Flanged. (Others on request).

SPECIFICATIONS

- Nominal Pressure:	According to dimensions and materials.
- Maximum operating temperature:	According to dimensions and materials.

OPTIONS

- Purge plugs.
- Specific connection.
- Nipples.
- Valves.